



# REFLECTION, DIFFRACTION, REFRACTION

## SECTION 7: CONVEX, PLANE AND CONCAVE MIRRORS ALL REFLECT LIGHT DIFFERENTLY

### PROCEDURE:

1. Place a sheet of loose leaf paper on the pin mat. Keep the long edge of the paper parallel to the edge of the work table.
2. Attach one each of the convex, concave, and plane mirrors to mirror brackets.. Refer to illustration on page 10 for mounting instructions.
3. Place the mirrors along the far edge of the paper, with the plane mirror in the center, convex (outwardly curved surface) to the left and concave (inwardly curved surface) mirror to the right.
4. From a distance of 50 cm, look into the mirrors. Observe your own image, and complete the chart below.

	Convex mirror	Plane Mirror	Concave Mirror
Can see entire Image of self			
Can see partial Image of self			
Image is blurred			
Upright Image			
Inverted Image			

5. Move your hand 10 cm from the mirror. Observe the reflections. What happens to the image of your hand in the convex mirror? Plane mirror? Concave mirror?
6. Place your pencil directly in front of the convex mirror, tip downward. Slowly move your pencil away from the mirror and observe the reflection. Repeat this with the plane and concave mirrors.

### Answer the following:

- a) As I move my pencil away from the mirror surface I notice that the image in the convex mirror \_\_\_\_\_.
- b) The image in the plane mirror \_\_\_\_\_.
- c) The image in the concave mirror \_\_\_\_\_.

7. Attach cap to flashlight, with slot positioned vertically.
8. Work area needs to be dark. Turn off lights in work area.
9. Stand slight to the side of the 3 mirrors. Focus the light beam onto each mirror, one at a time. Record the results of the following.
  - a) When light strikes the convex mirror.
  - b) When light strikes the plane mirror
  - c) When light strikes the concave mirror

### ADDITIONAL ACTIVITIES

- Observe different reflective surfaces and mirrors. Explain why a store security mirror is convex but a reflector around a headlight (or the flashlight!) is concave. What other purposes do concave and convex mirrors serve?
- A concave mirror will create a real image, an image that can be focused on a screen.) Prove this. The illustration below will guide you. A flashlight will work as your light source; a sheet of plain paper will do for a screen.

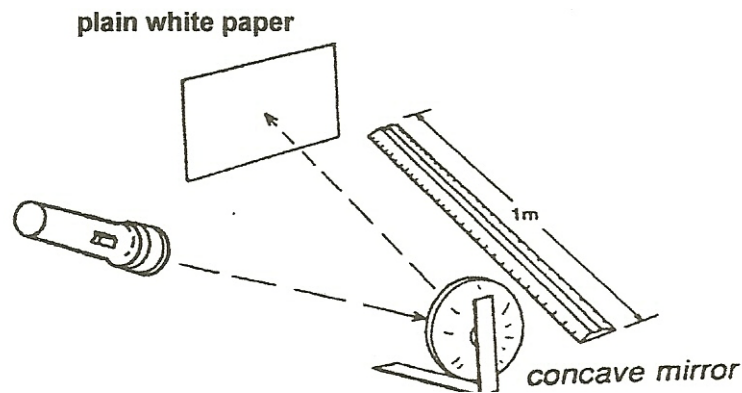

**Question:**

Does it work if you use the plane or convex mirrors?