

SERIES AND PARALELL CIRCUITS

LAB ELEC 2.COMP

From *Physics with Computers*, Vernier Software & Technology, 2003

INTRODUCTION

Components in an electrical circuit are in *series* when they are connected one after the other, so that the same current flows through both of them. Components are in *parallel* when they are in alternate branches of a circuit. Series and parallel circuits function differently. You may have noticed the differences in electrical circuits you use. When using some decorative holiday light circuits, if one lamp burns out, the whole string of lamps goes off. These lamps are in series. When a light bulb burns out in your house, the other lights stay on. Household wiring is normally in parallel.

You can monitor these circuits using a Current Probe and a Voltage Probe and see how they operate. One goal of this experiment is to study circuits made up of two resistors in series or parallel. You can then use Ohm's law to determine the equivalent resistance of the two resistors.

PURPOSE

The purpose is to study current flow and voltages in series and parallel circuits and to use Ohm's law to calculate equivalent resistance of series and parallel circuits.

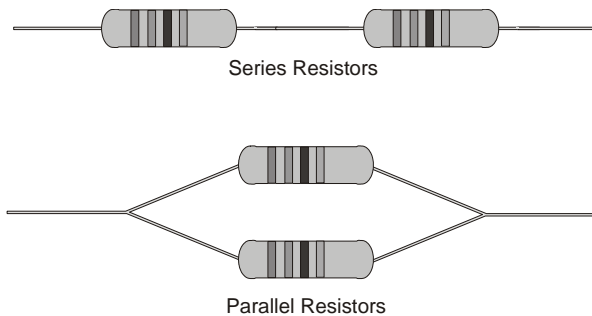

MATERIALS

Computer	Low-voltage DC power supply
LabPro or Universal Lab Interface	Two 10- Ω resistors
Logger <i>Pro</i>	Two 50- Ω resistors
Two Vernier Current Probes and one Vernier Differential Voltage Probe or, one Current & Voltage Probe System	Two 68- Ω resistors
	Momentary-contact switch
	Connecting wires

PRELIMINARY QUESTIONS

1. Using what you know about electricity, hypothesize about how series resistors would affect current flow. What would you expect the effective resistance of two equal resistors in series to be, compared to the resistance of a single resistor?
2. Using what you know about electricity, hypothesize about how parallel resistors would affect current flow. What would you expect the effective resistance of two equal resistors in parallel to be, compared to the resistance of one alone?
3. For each of the three resistor values you are using, note the *tolerance* rating. Tolerance is a percent rating, showing how much the actual resistance could vary from the labeled value. This value is labeled on the resistor or indicated with a color code. Calculate the range of resistance values that fall in this tolerance range.

Labeled resistor value (Ω)	Tolerance (%)	Minimum resistance (Ω)	Maximum resistance (Ω)

PROCEDURE

Part I Series Circuits

1. Connect the Current Probe to Channel 1 and the Differential Voltage Probe to Channel 2 of the interface.
2. Open the file “26a Series Parallel Circ” in the *Physics with Computers* folder. Current and voltage readings will be displayed in a meter.

Series and Parallel Circuits

3. Connect together the two voltage leads (red and black) of the Voltage Probe. Click , then click to zero both sensors. This sets the zero for both probes with no current flowing and with no voltage applied.

4. Connect the series circuit shown in Figure 2 using the $10\ \Omega$ resistors for resistor 1 and resistor 2. Notice the Voltage Probe is used to measure the voltage applied to both resistors. The red terminal of the Current Probe should be toward the + terminal of the power supply.

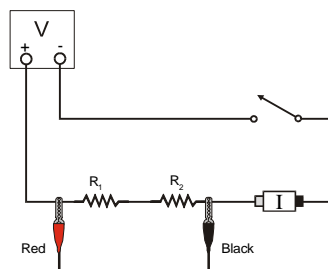

Figure 2

5. For this part of the experiment, you do not even have to click on the button. You can take readings from the meter at any time. To test your circuit, briefly press on the switch to complete the circuit. Both current and voltage readings should increase. If they do not, recheck your circuit.

6. Press on the switch to complete the circuit again and read the current (I) and total voltage (V_{TOT}). Record the values in the Data Table.

7. Connect the leads of the Voltage Probe across resistor 1. Press on the switch to complete the circuit and read this voltage (V_1). Record this value in the Data Table.

8. Connect the leads of the Voltage Probe across resistor 2. Press on the switch to complete the circuit and read this voltage (V_2). Record this value in the Data Table.

9. Repeat Steps 5 – 8 with a $50\ \Omega$ resistor substituted for resistor 2.

10. Repeat Steps 5 – 8 with a $50\ \Omega$ resistor used for both resistor 1 and resistor 2.

Part II Parallel circuits

11. Connect the parallel circuit shown below using $50\ \Omega$ resistors for both resistor 1 and resistor 2. As in the previous circuit, the Voltage Probe is used to measure the voltage applied to both resistors. The red terminal of the Current Probe should be toward the + terminal of the power supply. The Current Probe is used to measure the total current in the circuit.

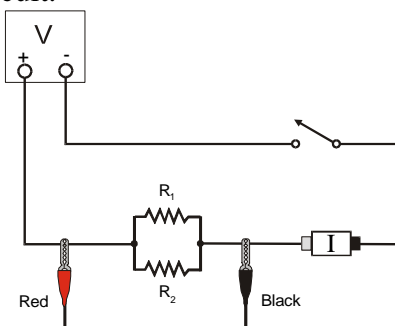

Figure 3

12. As in Part I, you can take readings from the meter at any time. To test your circuit, briefly press on the switch to complete the circuit. Both current and voltage readings should increase. If they do not, recheck your circuit.
13. Press the switch to complete the circuit again and read the total current (I) and total voltage (V_{TOT}). Record the values in the Data Table.
14. Connect the leads of the Voltage Probe across resistor 1. Press on the switch to complete the circuit and read the voltage (V_1) across resistor 1. Record this value in the Data Table.
15. Connect the leads of the Voltage Probe across resistor 2. Press on the switch to complete the circuit and read the voltage (V_2) across resistor 2. Record this value in the Data Table.
16. Repeat Steps 13 – 15 with a $68\ \Omega$ resistor substituted for resistor 2.
17. Repeat Steps 13 – 15 with a $68\ \Omega$ resistor used for both resistor 1 and resistor 2.

Part III Currents in Series and Parallel circuits

18. For Part III of the experiment, you will use two Current Probes. Open the experiment file “26b Series Parallel Circ.” Two graphs of current *vs.* time are displayed.
19. Disconnect the Voltage Probe and, into the same channel, connect a second Current Probe.
20. With nothing connected to either probe, click , then click to zero both sensors. This adjusts the current reading to zero with no current flowing.
21. Connect the series circuit shown in Figure 4 using the $10\ \Omega$ resistor and the $50\ \Omega$ resistor. The Current Probes will measure the current flowing into and out of the two resistors. The red terminal of each Current Probe should be toward the + terminal of the power supply.

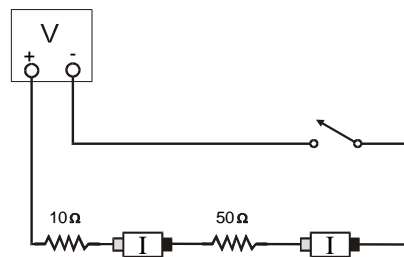



Figure 4

22. For this part of the experiment, you will make a graph of the current measured by each probe as a function of time. You will start the graphs with the switch open, close the switch for a few seconds, and then release the switch. Before you make any measurements, think about what you would expect the two graphs to look like. Sketch these graphs showing your prediction. Note that the two resistors are not equal.
23. Click on the **Collect** button, wait a second or two, then press on the switch to complete the circuit. Release the switch just before the graph is completed.
24. Select the region of the graph where the switch was on by dragging the cursor over it. Click on the Statistics button, , and record the average current in the Data Table. Determine the average current in the second graph following the same procedure.
25. Connect the parallel circuit as shown in Figure 5 using the $50\ \Omega$ resistor and the $68\ \Omega$ resistor. The two Current Probes will measure the current through each resistor individually. The red terminal of each Current Probe should be toward the + terminal of the power supply.

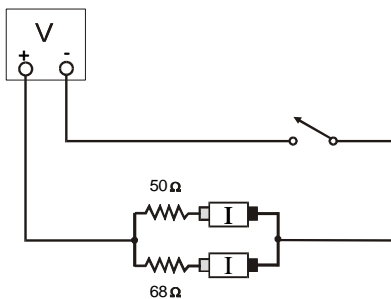



Figure 5

26. Before you make any measurements, sketch your prediction of the current vs. time graphs for each Current Probe in this configuration. Assume that you start with the switch open as before, close it for several seconds, and then open it. Note that the two resistors are not identical in this parallel circuit.
27. Click on the **Collect** button and wait a second or two. Then press on the switch to complete the circuit. Release the switch just before the graph is completed.
28. Select the region of the graph where the switch was on by dragging the cursor over it. Click on the Statistics button, , and record the average current in the Data Table. Determine the average current in the second graph following the same procedure.

DATA TABLE

Part I Series Circuits

Part I: Series circuits							
	R_1 (Ω)	R_2 (Ω)	I (A)	V_1 (V)	V_2 (V)	R_{eq} (Ω)	V_{TOT} (V)
1	10	10					
2	10	50					
3	50	50					

Part II: Parallel circuits							
	R_1 (Ω)	R_2 (Ω)	I (A)	V_1 (V)	V_2 (V)	R_{eq} (Ω)	V_{TOT} (V)
1	50	50					
2	50	68					
3	68	68					

Part III: Currents				
	R_1 (Ω)	R_2 (Ω)	I_1 (A)	I_2 (A)
1	10	50		
2	50	68		

ANALYSIS

1. Examine the results of Part I. What is the relationship between the three voltage readings: V_1 , V_2 , and V_{TOT} ?
2. Using the measurements you have made above and your knowledge of Ohm's law, calculate the equivalent resistance (R_{eq}) of the circuit for each of the three series circuits you tested.

3. Study the equivalent resistance readings for the series circuits. Can you come up with a rule for the equivalent resistance (R_{eq}) of a series circuit with two resistors?
4. For each of the three series circuits, compare the experimental results with the resistance calculated using your rule. In evaluating your results, consider the tolerance of each resistor by using the minimum and maximum values in your calculations.
5. Using the measurements you have made above and your knowledge of Ohm's law, calculate the equivalent resistance (R_{eq}) of the circuit for each of the three parallel circuits you tested.
6. Study the equivalent resistance readings for the parallel circuits. Devise a rule for the equivalent resistance of a parallel circuit of two resistors.
7. Examine the results of Part II. What do you notice about the relationship between the three voltage readings V_1 , V_2 , and V_{TOT} in parallel circuits.
8. What did you discover about the current flow in a series circuit in Part III?
9. What did you discover about the current flow in a parallel circuit in Part III?
10. If the two measured currents in your parallel circuit were not the same, which resistor had the larger current going through it? Why?

EXTENSIONS

1. Try this experiment using three resistors in series and in parallel.
2. Try Part III of this experiment using small lamps instead of resistors. Can you explain the change in the shape of the current vs. time graphs?

